

This print-out should have 11 questions. Multiple-choice questions may continue on the next column or page – find all choices before answering. The due time is Central time.

Please notice that for your homework to be considered towards your grade, it needs to be submitted one hour before the corresponding recitation starts. Work submitted after this time, but before the DUE DATE on top of this page, will be accepted but not graded.

PLEASE REMEMBER THAT YOU MUST CARRY OUT YOUR CALCULATIONS TO AT LEAST THREE SIGNIFICANT FIGURES. YOUR ANSWER MUST BE WITHIN ONE PERCENT OF THE CORRECT RESULT TO BE MARKED AS CORRECT BY THE SERVER.

001 (part 1 of 1) 6 points

A 84.8 turns circular coil with a radius 8.29 cm and a resistance 1.91Ω is placed in a magnetic field directed perpendicular to the plane of the coil. The magnitude of the magnetic field varies in time according to the expression

$$B = a_1 t + a_2 t^2,$$

where $a_1 = 0.0894 \text{ T/s}$, $a_2 = 0.0287 \text{ T/s}^2$ are constants, time t is in seconds and field B is in Tesla.

Calculate the magnitude of the induced \mathcal{E} in the coil at $t = 8.73 \text{ s}$. Answer in units of V.

002 (part 1 of 1) 6 points

A circular wire loop of radius 5.1 m lies in a plane perpendicular to a uniform magnetic field of magnitude 0.4 T. In 0.1 s the wire is reshaped into a square but remains in the same plane.

What is the magnitude of the average induced emf in the wire during this time? Answer in units of V.

003 (part 1 of 2) 5 points

In the arrangement shown in the figure, the resistor is 2Ω and a 7 T magnetic field is directed into the paper. The separation between the rails is 5 m. Neglect the mass of

the bar.

An applied force moves the bar to the right at a constant speed of 4 m/s. Assume the bar and rails have negligible resistance and friction.

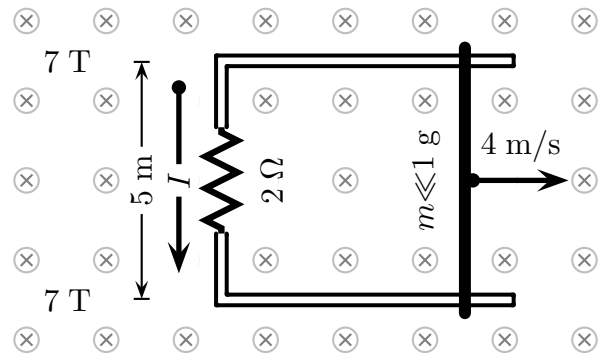

Calculate the applied force required to move the bar to the right at a constant speed of 4 m/s. Answer in units of N.

004 (part 2 of 2) 5 points

At what rate is energy dissipated in the resistor? Answer in units of W.

005 (part 1 of 1) 6 points

A car with a 0.886 m long radio antenna travels at 38.7 km/h in a place where the Earth's magnetic field is $2.91 \times 10^{-5} \text{ T}$.

What is the maximum possible induced emf in the antenna as it moves through the Earth's magnetic field? Answer in units of V.

006 (part 1 of 1) 6 points

A metal bar is sliding across the surface of a metal ring, as shown in the figure. There is a uniform magnetic field directed into the paper.

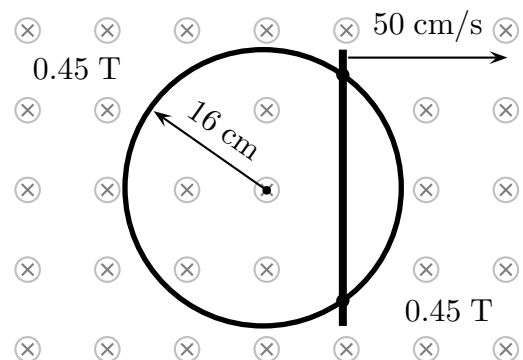

What is the magnitude of the induced emf,

\mathcal{E} , in the rod when it is a distance 4.6 cm from the center of the ring? Answer in units of V.

007 (part 1 of 2) 3 points

A metal bar with length $\overline{OA} = L$ is rotating in a counter-clockwise manner about the point O with a constant angular velocity ω . There is a constant magnetic field B directed out of the paper.

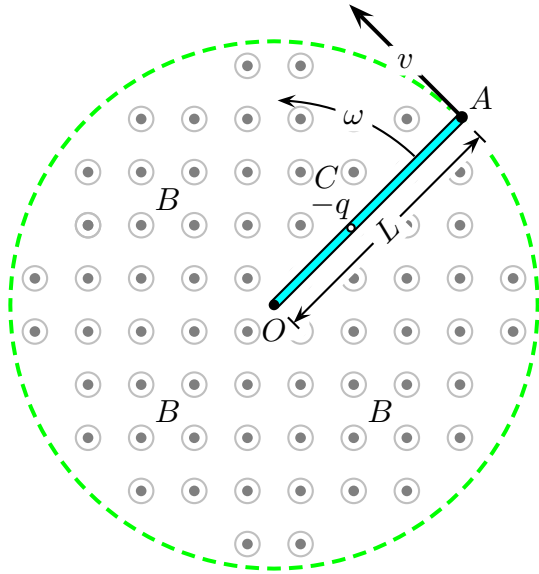

The direction of the magnetic force on the negative charge $-q$ at a fixed point C due to the magnetic field, and the relationship between V_O and V_A are respectively given by

1. radially inward, $V_O = V_A$.
2. radially outward, $V_O > V_A$.
3. radially inward, $V_O > V_A$.
4. out of the plane, $V_O = V_A$.
5. in the plane, $V_O = V_A$.
6. in the direction of \vec{v} , $V_O = V_A$.
7. radially outward, $V_O = V_A$.
8. radially inward, $V_A > V_O$.
9. opposite to the direction of \vec{v} , $V_O = V_A$.

10. radially outward, $V_A > V_O$.

008 (part 2 of 2) 3 points

The length of the bar is 10 m and the magnitude of the magnetic field is 9 T.

The speed of the bar at point C is 55 m/s, and the length of $\overline{OC} = 5$ m.

Determine the magnitude of the potential difference $|V_O - V_A|$.

1. $|V_O - V_A| = 4950$ V
2. $|V_O - V_A| = 990$ V
3. $|V_O - V_A| = 9900$ V
4. $|V_O - V_A| = 495$ V
5. $|V_O - V_A| = \frac{495}{4}$ V
6. $|V_O - V_A| = 1980$ V
7. $|V_O - V_A| = 19800$ V
8. $|V_O - V_A| = \frac{1485}{2}$ V
9. $|V_O - V_A| = \frac{990}{7}$ V
10. $|V_O - V_A| = \frac{495}{2}$ V

009 (part 1 of 2) 3 points

An automobile has a vertical radio antenna 1.33 m long. The automobile travels at 97.3 km/h on a horizontal road where Earth's magnetic field is $50.3 \mu\text{T}$ directed toward the north and downward at an angle of 43.3° below the horizontal.

Specify the direction that the automobile should move in order to generate the maximum motional emf in the antenna, with the top of the antenna positive relative to the bottom.

1. north
2. south
3. east

4. west

5. Unable to determine.

010 (part 2 of 2) 4 points

Find the magnitude of this induced emf. Answer in units of V.

011 (part 1 of 1) 3 points

A magnetic field that is decreasing with time is directed out of the page and passes through a circular loop of wire in the plane of the page.

Which of the following is true of the induced current in the wire loop?

1. It is zero in magnitude.
2. It is counterclockwise in direction.
3. It is clockwise in direction.
4. It is directed into the page.
5. It is directed out of the page.